



KGS-810F Ver.B



Web Smart 8-Port L2 Gigabit Ethernet Switch with 1 GbE SFP Port

Product Highlights:

- Web management
- One 1000M SFP fiber
- DHCP support
- 802.1Q Tagged VLAN support
- QoS WFQ support
- Port mirroring function
- 802.1x port access control
- RSTP and MSTP support
- LACP link aggregation
- Jumbo frame support
- IGMP snooping
- High power saving

Key Features:

- Provides 8 10/100/1000Mbps RJ-45 and 1 Mini-GBIC SFP slot
- Provides in-band web and SNMP management interfaces
- All copper ports support auto-negotiation and auto-MDI/MDI-X detection
- Provides full wire speed forwarding
- Supports jumbo frame at all speeds
- Supports 802.3x flow control for full-duplex and backpressure for half-duplex
- Provides port status, statistic monitoring and control function
- Provides DHCP client & static IP configuration
- Supports port-based and 802.1Q Tag-based VLAN
- Provides QoS function
- Provides port link aggregation (trunking) function with LACP support
- Provides port mirroring function
- Provides 802.1x authentication for port access
- Supports 802.1w RSTP and 802.1s MSTP
- Provides IGMP snooping
- Supports SFP with Digital Diagnostic Monitoring (DDM)

DIN-Rail Mounting Bracket
KC-4DR



Panel Mounting Bracket
PMB-810



Specifications:

Standard	IEEE 802.3, 802.3ab, 802.3z, 802.3x, 802.1x, 802.1w, 802.1s, 802.1Q
Network Ports	7 10/100/1000Mbps Gigabit copper ports Shielded RJ-45, auto-negotiation, auto-MDI/MDI-X support 1 1000Mbps Gigabit fiber SFP port SFP supports standard SFP fiber transceiver installation
Network Cables	10/100/1000Mbps copper: Cat.5 up to 100m 1000Base-X: 62.5/125µm, 50/125µm MM fiber, 9/125µm SM fiber
MAC Addresses	Table with 8K entries
IP Multicast Groups	8K
Buffer Memory	176K bytes
VLAN Function	Port based VLAN, 8021Q Tag-based VLAN
Port Link Aggregation	LACP (802.3ad) support
QoS Function	4 priority queues, Classification: Port-based, 802.1p, IP DSCP
LED Indication	Per unit: Power Per copper port: 1000M, 100M, 10M speed/link/activity status SFP port: 1000M speed/link/activity status, Optical link status
Management Support	Web browser software, SNMP MIB-2
Management Objects	System settings, Port status/statistics, Port control, VLAN, QoS, LACP aggregation, port mirroring, Firmware upgrade, 802.1w RSTP, 802.1x, IGMP snooping, Storm control, Power saving, Configuration backup and restore



Environment	Operating Temperature: -5°C ~ 50°C (Main device) Storage Temperature: -20°C ~ 85°C Relative Humidity: 10% ~ 90% non-condensing
Dimension	180 x 114 x 26 mm (WxDxH)
Power Input	+5V ~ +12VDC (+/-5%) via external power adapter
Power Consumption	7.3W max. @+5V (DC IN) Less than 1.1W when no link ports under power saving mode
Approval	FCC Class A, VCCI Class A, CE mark Class A

Optional Accessories:

KC-4DR	DIN-Rail mounting bracket
PMB-810	Panel mounting bracket
KTI quality SFP transceivers	

Dimension

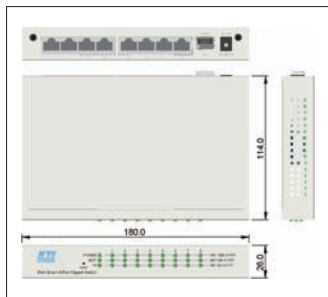

Applications:

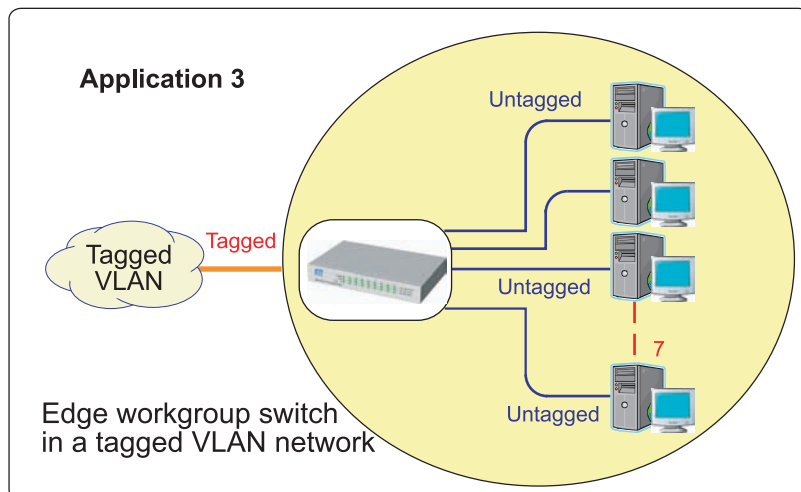
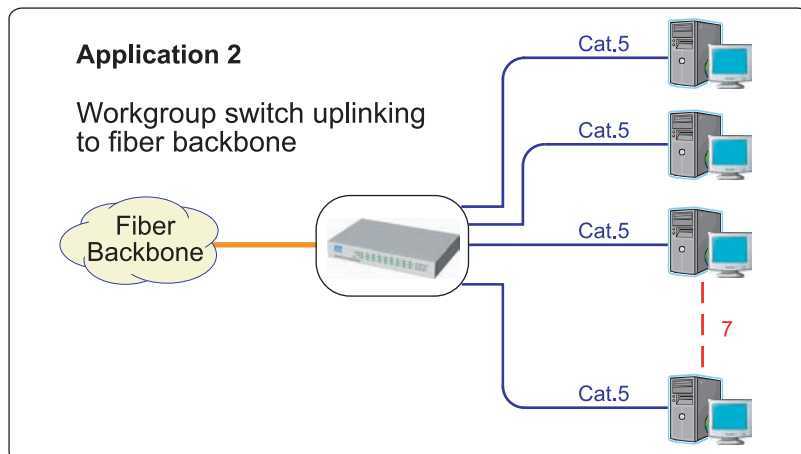
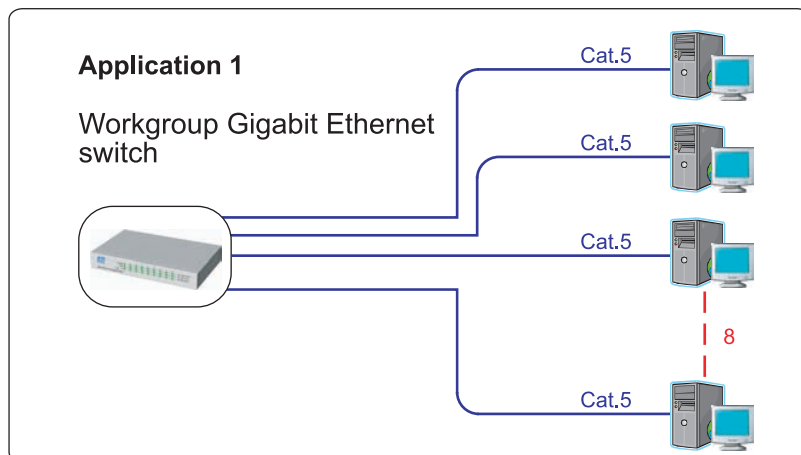

FCC Part 15, Class A
CISPR 22 Class A
VCCI Class A

Katron Technologies Inc.

15F-7, No. 79, Sec. 1, Hsin Tai Wu Rd.,
Hsi-chih, New Taipei City, Taiwan, R.O.C.
Tel: 886-2-2698-3878
Fax: 886-2-2698-3873
E-mail: kti@ktinet.com.tw
URL: <http://www.ktinet.com.tw>

KTI Networks Inc.

10415-A Westpark Drive, Houston,
TX 77042, U.S.A.
Tel: 1-713-266-3891
Fax: 1-713-914-0555
E-mail: contact@ktinet.com
URL: <http://www.ktinet.com>

Trademarks: All brand names are trademarks or registered trademarks of their respective holders.
This information is subject to change without prior notice.